

## 4145... (EK) with external coolant supply

Item No.	Turret specification			Clamping system d	Dimensions/Data					
	D	Turret manufacturer	Drive coupling		L <sub>1</sub>	L <sub>2</sub>	H <sub>3</sub>	max. stroke RPM	M Nm	I n <sub>1</sub> :n <sub>2</sub>
414516000-45	45	BMT 45P	DIN 1809	16	103	70	95,5	1000	25	1:1
414516001-55	55	BMT 55P	DIN 1809	16	103	70	95,5	1000	25	1:1
414516000-55	55	BMT 55P	DIN 1809	16	118	85	95,5	1000	25	1:1
414516001-65	65	BMT 65P	DIN 1809	16	113	80	95,5	1000	25	1:1
414516000-65	65	BMT 65P	DIN 1809	16	133	100	95,5	1000	25	1:1
414516003-30	30	EMCO Hyperturn / Maxturn 65	DIN 5480	16	133	100	95,5	1000	25	1:1
414516006-40	40	EMCO Hyperturn 95/110/690	DIN 5480	16	133	100	95,5	1000	25	1:1
414516001-30L/R	30	Gildemeister, Trifix®	DIN 5480	16	133	100	95,5	1000	25	1:1
414516007-40L/R	40	Gildemeister, Trifix®	DIN 5480	16	133	100	95,5	1000	25	1:1
414516002-30	30	Index C200, G250-300, MS52	1-step	16	123	90	95,5	1000	25	1:1
414516010-40	40	Mazak HQR 100-150 MSY	DIN 1809	16	148	115	95,5	1000	25	1:1
414516011-40	40	Mazak HQR 200-250 MSY	DIN 1809	16	163	130	95,5	1000	25	1:1
414516009-40	40	Mazak QTN 100 M(S)	DIN 1809	16	133	100	95,5	1000	25	1:1
414516008-40	40	Mazak QTN 200-250 M(S)	DIN 1809	16	163	130	95,5	1000	25	1:1
414516002-50	50	Mazak QTN 300-450 M(S)	DIN 1809	16	183	150	95,5	1000	25	1:1
414516000-68	68	Mazak QTS 100-250 M	DIN 1809	16	113	80	95,5	1000	25	1:1
414516000-80	80	Mazak QTS 300,350 M	DIN 1809	16	133	100	95,5	1000	25	1:1
414516000-40	40	Mori Seiki NZX 1500-2000 <sup>1)</sup>	DIN 1809	16	118	85	95,5	1000	25	1:1
414516000-60	60	Mori Seiki NLX 1500-4000 <sup>2)</sup>	DIN 1809	16	133	100	95,5	1000	25	1:1
414516003-65	65	Nakamura-Tome WT-300	DIN 1809	16	118	85	95,5	1000	25	1:1
414516002-65	65	Nakamura-Tome Super Mill	DIN 1809	16	101	68	95,5	1000	25	1:1
414516002-55	55	Okuma LT 2000 V16	DIN 1809	16	113	80	95,5	1000	25	1:1
414516001-60	60	Okuma LB 2000-3000	DIN 1809	16	113	80	95,5	1000	25	1:1
414516002-60	60	Okuma LB 4000	DIN 1809	16	118	85	95,5	1000	25	1:1
414516003-60	60	Okuma LT 3000	DIN 1809	16	123	90	95,5	1000	25	1:1
414516000-30	30	Sauter/Diplomatic	DIN 5480	16	118	85	95,5	1000	25	1:1
414516001-40	40	Sauter/Diplomatic	DIN 5480	16	133	100	95,5	1000	25	1:1
414516004-60	60	Takisawa TS-3000/4000 T12	DIN 1809	16	133	100	95,5	1000	25	1:1

Dimensions in mm

<sup>1)</sup> Suitable for: NZ/NZX 1500-2500 (16 station turret); NL/NLX 1500-2500 (20 station turret); NT/NTX 1000, 2000; NT 3100, 3150, 3200; DuraTurn 2050, 2550 MC

<sup>2)</sup> Suitable for: NL/NLX 1500-3000 (10/12 station turret); NZX 2500 (12 station turret); NT 4200-5400

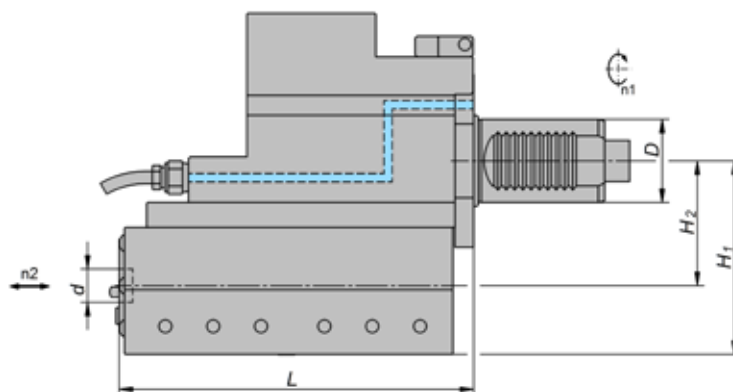

## 4141... (EK) with external coolant supply

Item No.	Turret specification			Clamping system d	Dimensions/Data					
	D	Turret manufacturer	Drive coupling		L	H <sub>1</sub>	H <sub>2</sub>	max. stroke RPM	M Nm	I n <sub>1</sub> :n <sub>2</sub>
414116003-30	30	Baruffaldi	TBMA 160	16	170	93	60	1000	25	1:1
414116002-30	30	Duplomatic	DIN 1809	16	170	93	60	1000	25	1:1
414116000-30	30	Sauter	DIN 5480	16	170	93	60	1000	25	1:1
414116001-30	30	Sauter	DIN 5482	16	170	93	60	1000	25	1:1
414116006-40	40	Baruffaldi	TBMA 200	16	170	93	60	1000	25	1:1
414116004-40	40	Duplomatic	DIN 1809	16	170	93	60	1000	25	1:1
414116001-40	40	Haas ST-20/30, DS-30	1-step	16	170	93	60	1000	25	1:1
414116005-40	40	Okuma Genos L300	1-step	16	170	93	60	1000	25	1:1
414116002-40	40	Sauter	DIN 5480	16	170	93	60	1000	25	1:1
414116003-40	40	Sauter	DIN 5482	16	170	93	60	1000	25	1:1

Dimensions in mm